

FINAL EXAM, P221 Fall 2004, Dec. 17, 2004

Your Name _____

Discussion Section Time _____

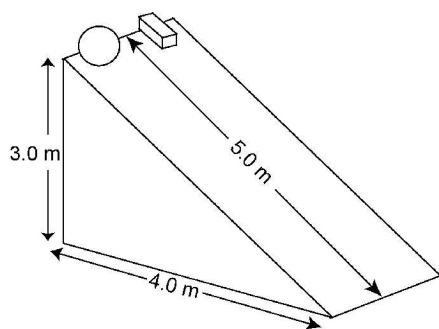

1. A uniform solid sphere and a rectangular block are released from rest at the same moment, at the top of an inclined ramp of height 3.0 m. The sphere rolls without slipping down the incline, while the block slides subject to kinetic friction between it and the ramp surface. The sphere and the block are observed to travel the 5.0 m down to the bottom of the ramp in equal time intervals, and to arrive at the bottom with equal center-of-mass velocities.

a) [5 points] Circle the statement below that best describes the energies of the sphere and the block during their motion down the ramp:

- i) Mechanical energy is conserved for the sphere, which is subject to static friction, but is reduced by kinetic friction for the block.
- ii) Mechanical energy is conserved for both the sphere and the block.
- iii) Mechanical energy is reduced by friction for both the sphere and the block.
- iv) Mechanical energy is conserved for the block, but is increased for the sphere by static friction, which causes its rotation.
- v) The translational kinetic energy at the bottom of the ramp is equal to the gravitational potential energy at the top, for both sphere and block.

b) [7 points] Analyze the sphere to determine the common **center-of-mass speed at the bottom of the ramp**, for both sphere and block.

c) [8 points] Analyze the block's motion to find the **coefficient of kinetic friction** μ_k between the block and the ramp.

FINAL EXAM, P221 Fall 2004, Dec. 17, 2004

Your Name _____

Discussion Section Time _____

2. Pucks on an air hockey table move without friction on a thin layer of air. As shown in the diagram, a puck initially at rest, and wrapped with Velcro around its circumference, undergoes a completely inelastic collision with a second identical puck, which is initially moving at constant speed $v_0 = 0.50$ m/s, along a line leading to a glancing collision of the two pucks. The pucks are each uniform disks of mass $m = 0.15$ kg and radius $R = 0.10$ m. During the collision, **there is no net external force or torque** acting on the two-puck system. After the collision, the combined system moves off with a center-of-mass velocity v_f and simultaneously rotates at angular velocity ω_f about an axis through the system's center of mass (*i.e.*, the contact point between the two rims).

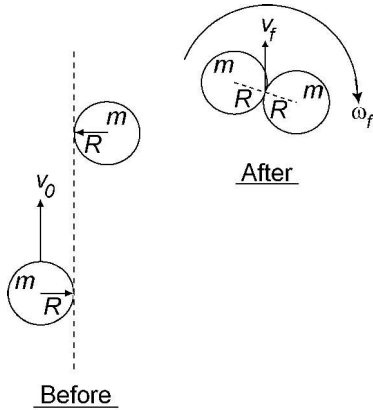

a) [5 points] Find the **final center-of-mass speed** v_f of the combined two-puck system.

b) [5 points] Find the **rotational inertia** of the two-puck system about the axis through the combined center of mass.

c) [5 points] Find the **final angular speed** ω_f of the combined two-puck system.

d) [5 points] How much **mechanical energy is lost** during the inelastic collision?

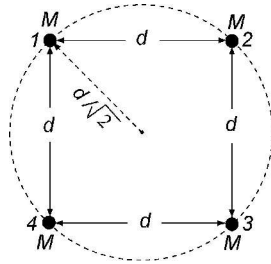

3. Four stars of equal mass M are arranged at the corners of a square of side length d . The diagonally opposite stars are thus a distance $d\sqrt{2}$ apart. Answer the questions below in terms of G , M and d .

a) [9 points] Find the **net gravitational force vector** (magnitude and direction) exerted by the other three stars on the star labeled '1' in the diagram above.

b) [6 points] Under the influence of their mutual gravitational attraction, the four stars can orbit their common center of mass in the circle of radius $d/\sqrt{2}$ indicated by a dashed line in the diagram above. Each of the stars has the same orbital speed, so that they always remain the same distance apart. Find the **orbital speed** of the stars.

c) [5 points] A comet passing through the center of the 4-star system may eventually escape completely from the stars' gravitational pull (circle the best answer):

- i) only if it reaches the c.m. of the star system with zero velocity.
- ii) only if it reaches the c.m. of the star system with zero acceleration.
- iii) only if its total mechanical energy at the center of the star system is not negative.
- iv) only if its gravitational potential energy at the center of the star system is zero (relative to its value at an infinite distance from the stars).
- v) under no circumstances – it remains trapped forever since it feels a gravitational attraction to the stars.

Your Name _____

Discussion Section Time _____

4. A long uniform pole with a mass of $m = 30$ kg and a length of $L = 10$ m is suspended from the ceiling of the building. An acrobat with a mass of $M = 50$ kg and initially at rest, swings from platform **A** to the platform **B** by holding on the end of the pole as shown. The initial deviation of the acrobat from equilibrium is $\theta = 1.5^\circ$. Neglect any friction and air resistance.

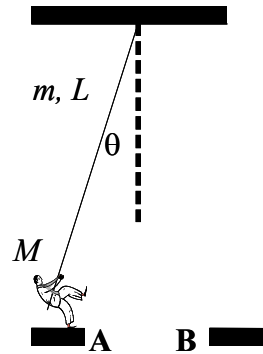

a) [4 points] Find the **rotational inertia** of the acrobat + pole physical pendulum system about the point of suspension.

b) [6 points] **How long does it take** for the acrobat to swing from platform **A** to platform **B**? Platform **B** is symmetrical to **A** with respect to the equilibrium position of the pole.

c) [6 points] Find the **maximum linear speed** of the acrobat during the swing.

d) [4 points] Assume that the horizontal distance between platforms **A** and **B** is doubled. What will happen to the time from part (b) and to the velocity from part (c)? Circle the best answer:

- i) The time and the velocity will both increase.
- ii) The time will increase but the velocity will remain the same.
- iii) The time and the velocity will both remain the same.
- iv) The time and the velocity will both decrease.
- v) The time will remain the same but the velocity will increase.

FINAL EXAM, P221 Fall 2004, Dec. 17, 2004

Your Name _____

Discussion Section Time _____

5. A transverse standing wave is created on a string that is stretched between fixed ends at $x = -1.5$ m and $x = 1.5$ m. The wave has a node at $x = 0.5$ m and an antinode at $x = 0.0$ m. The displacement y of the string at $x = 0.0$ m is shown in the figure as a function of time.

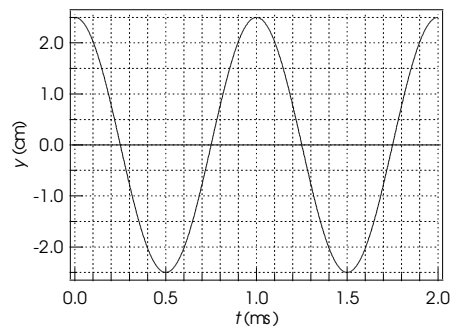

a) [4 points] Draw a sketch of this wave along the x – axis at time $t = 0$ on the graph below.

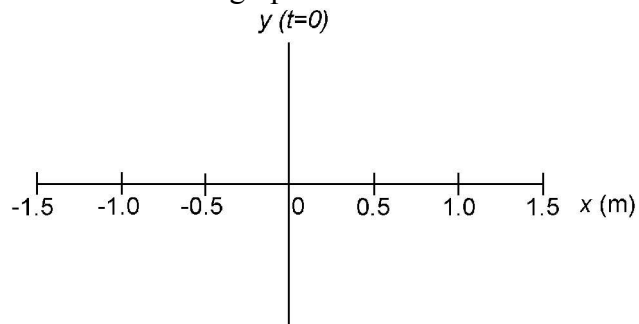

b) [4 points] Find the **period** and the **wavelength** of the wave.

c) [6 points] Find the string displacement (**magnitude** and **sign**) at $x = 1.0$ m and $t = 0.5$ ms. Explain your reasoning.

d) [6 points] If the linear density of the string is $\mu = 0.05$ kg/m, find the **tension** in the string.